



# YETDA INDUSTRY LTD.

## Technical Data Sheet

**MODEL NO: Q150YG4-R**

**1206 Reverse Mounted SMD (3.2 x 1.6mm)**

**Features :**

- Package in 8mm tape on 7" diameter reel
- Compatible with automatic placement equipment
- Compatible with reflow solder process

**Applications :**

- Indicators
- Automotive : backlighting in dashboard and switch
- Backlight for LCD

Dice material	Emitted color	Lens Color
AlGaInP	Green	Water clear

**Electrical/Optical Characteristics(Ta=25°C)**

Parameter	Test Condition	Symbol	Value			Unit
			Min	Typ	Max	
Dominant wavelength	I <sub>F</sub> =20mA	λ <sub>d</sub>	566		576	nm
Spectral half bandwidth	I <sub>F</sub> =20mA	Δλ		16		nm
Forward voltage	I <sub>F</sub> =20mA	V <sub>F</sub>	1.8		2.4	V
Luminous intensity	I <sub>F</sub> =20mA	I <sub>v</sub>	20	25		mcd
Viewing angle at 50% I <sub>v</sub>	I <sub>F</sub> =10mA	2 θ 1/2		120		Deg
Reverse current	V <sub>R</sub> =5V	I <sub>R</sub>			10	μA

**Absolute Maximum Ratings(Ta=25°C)**

Parameter	Symbol	Value	Unit
Power dissipation	P <sub>d</sub>	72	mW
Forward current	I <sub>F</sub>	30	mA
Reverse voltage	V <sub>R</sub>	5	V
Operating temperature range	T <sub>op</sub>	-40 ~+80	°C
Storage temperature range	T <sub>stg</sub>	-40 ~+85	°C
Peak pulsing current (1/8 duty f=1kHz)	I <sub>FP</sub>	125	mA



# YETDA INDUSTRY LTD.

## PACKAGING DIMENSIONS (mm):

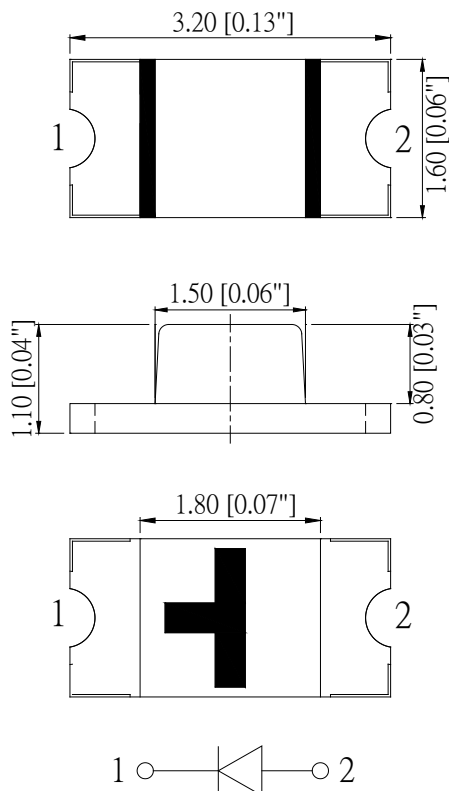

## Recommend Pad Layout

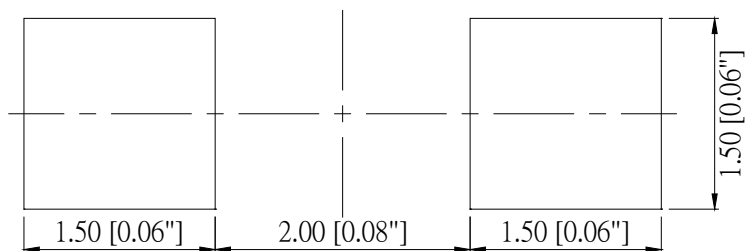

<b>Precautions For Use :</b>
<b>Over - current - proof</b>
Customer must apply resistors for protection, otherwise slight voltage shift will cause big current change ( Burn out will happen )
<b>Storage</b>
1. The operation of temperature and R.H. are : $5^{\circ}\text{C} \sim 30^{\circ}\text{C}$ , 60%R.H. Max.
2. Once the package is opened, the products should be used within a week. Otherwise, they should be kept in a dampproof box with desiccating regent. Considering the tape life, we suggest our customers to use our products within 1.5 year ( from production date ) .
3. It's recommended to bake before soldering when the package is unsealed after 72 hrs. The condition is : $60^{\circ}\text{C} \pm 5^{\circ}\text{C}$ for 15hrs.



# YETDA INDUSTRY LTD.

## ■ Typical Electro-Optical Characteristics Curve:

Fig 1. Forward Current vs. Forward Voltage

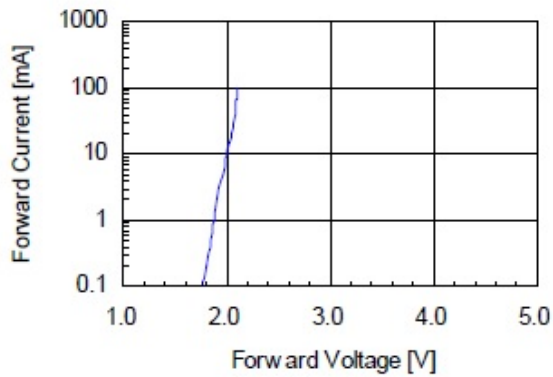

Fig 2. Relative Intensity vs. Forward Current

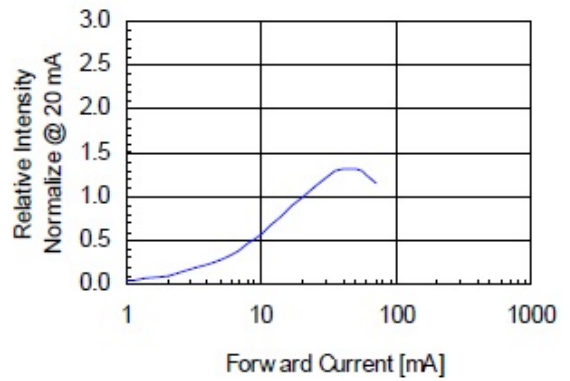

Fig 3. Forward Voltage vs. Temperature

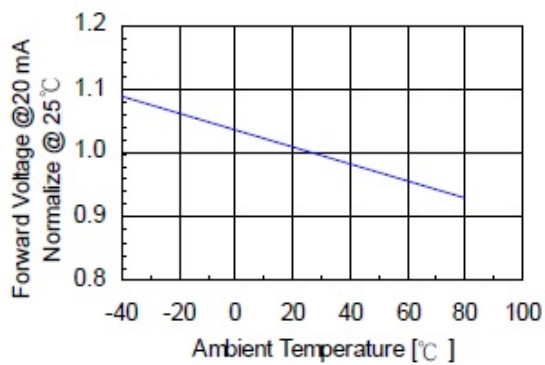

Fig 4. Relative Intensity vs. Temperature

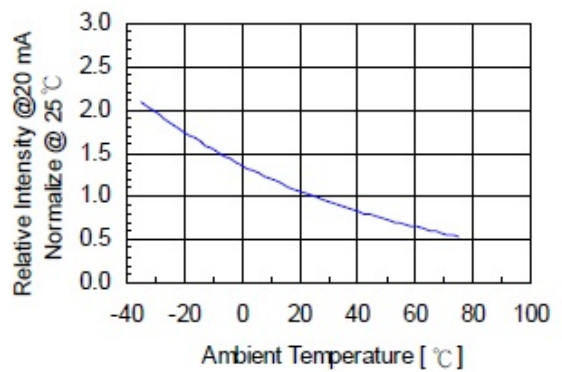
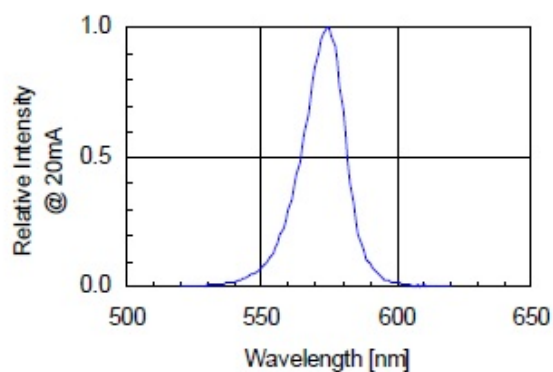

Fig 5. Relative Intensity vs. Wavelength





# YETDA INDUSTRY LTD.

## ■ Reflow Temp/Time

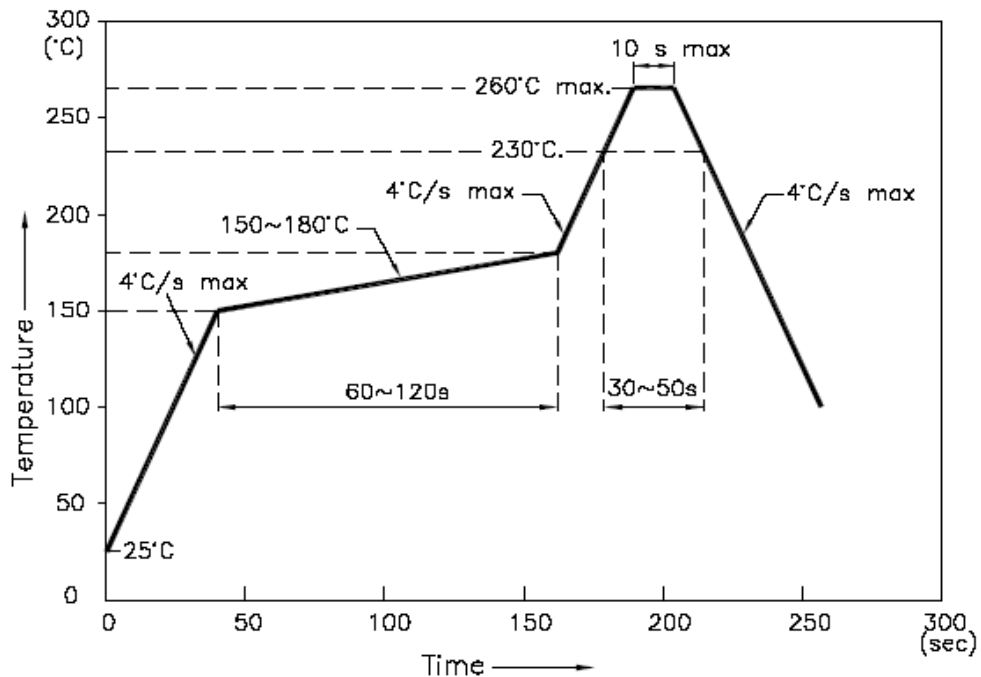

### NOTES:

1. We recommend the reflow temperature  $245^{\circ}\text{C} (\pm 5^{\circ}\text{C})$ . the maximum soldering temperature should be limited to  $260^{\circ}\text{C}$ .
2. dont cause stress to the epoxy resin while it is exposed to high temperature.
3. Number of reflow process shall be 2 times or less.

## ■Soldering iron

Basic spec is  $\leq 5\text{sec}$  when  $260^{\circ}\text{C}$ . If temperature is higher, time should be shorter ( $+10^{\circ}\text{C} \rightarrow -1\text{sec}$ ). Power dissipation of iron should be smaller than 20W, and temperatures should be controllable. Surface temperature of the device should be under  $230^{\circ}\text{C}$ .

## ■Rework

1. Customer must finish rework within 5 sec under  $260^{\circ}\text{C}$ .
2. The head of iron can not touch copper foil
3. Twin-head type is preferred.

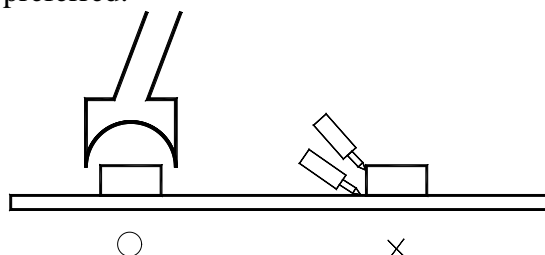

■ Avoid rubbing or scraping the resin by any object, during high temperature, for example reflow 、 solder etc.



# YETDA INDUSTRY LTD.

## Packaging Specifications

- Feeding Direction

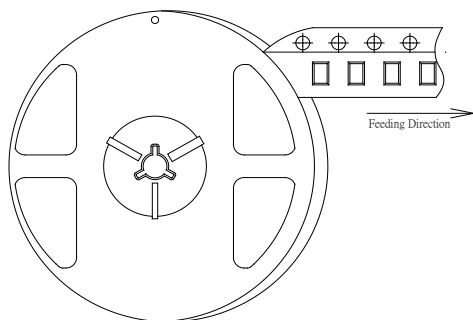

- Dimensions of Reel (Unit: mm)

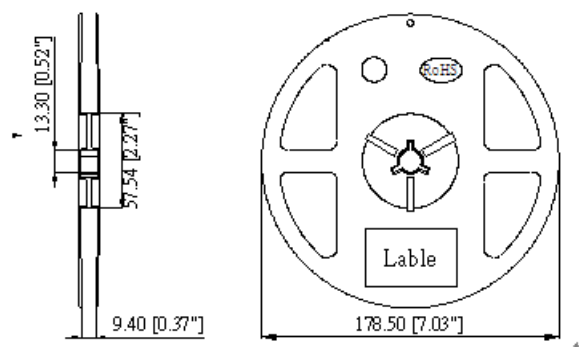

- Dimensions of Tape (Unit: mm)

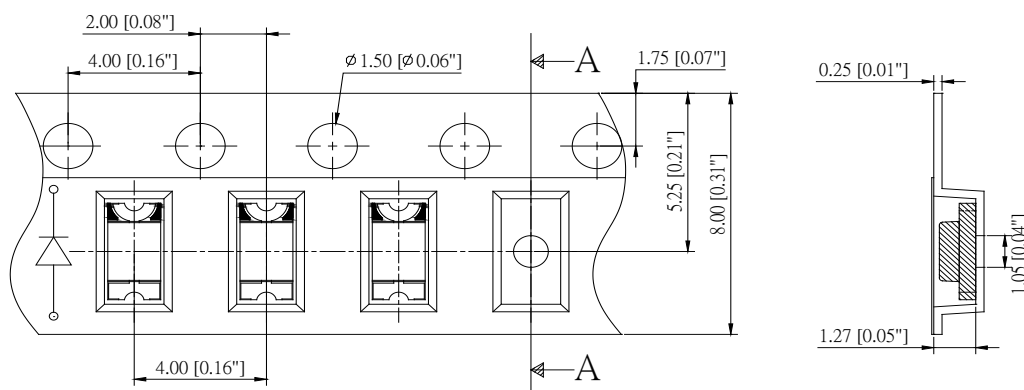

- Arrangement of Tape

