



YETDA INDUSTRY LTD.

Technical Data Sheet

MODEL NO : Q776NNH4-G

Package 3.2*2.7*1.8 mm Top LEDs

Features :

- Lens Molding
- Compatible with automatic placement equipment
- Compatible with reflow solder process

Applications :

- Indicators
- Automotive : backlighting in dashboard and switch
- Backlight for LCD

Dice material	Emitted color	Lens Color
AlGaInP	Red	Water transparent

Electrical/Optical Characteristics(Ta=25°C)

Parameter	Test Condition	Symbol	Value			Unit
			Min	Typ	Max	
Wavelength at peak emission	IF=50mA	λ peak		630		nm
Dominant wavelength	IF=50mA	λ D	615	620	630	nm
Forward voltage	IF=50mA	VF	1.9	2.1	2.9	V
Luminous intensity	IF=50mA	Iv	1250	2050	4000	mcd
Viewing angle at 50% Iv	IF=10mA	2 θ 1/2		120		Deg
Reverse current	VR=5V	IR			10	μ A

Absolute Maximum Ratings(Ta=25°C)

Parameter	Symbol	Value	Unit
Power dissipation	Pd	145	mW
Forward current	IF	50	mA
Reverse voltage	VR	5	V
Operating temperature range	Top	-40 ~+80	°C
Storage temperature range	Tstg	-40 ~+85	°C
Peak pulsing current (1/8 duty f=1kHz)	I _{fp}	125	mA

2016APR08Y



YETDA INDUSTRY LTD.

PACKAGING DIMENSIONS

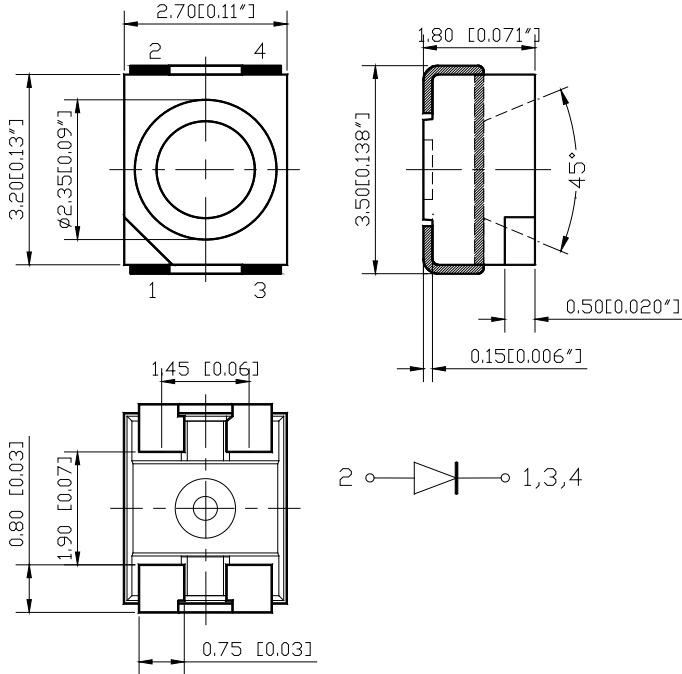

RECOMMEND PAD LAYOUT

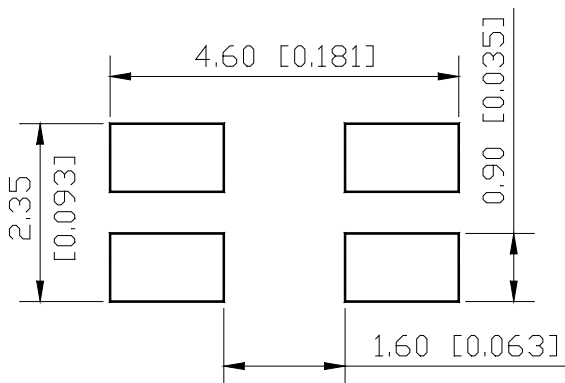



YETDA INDUSTRY LTD.

Typical Electro-Optical Characteristics Curve:

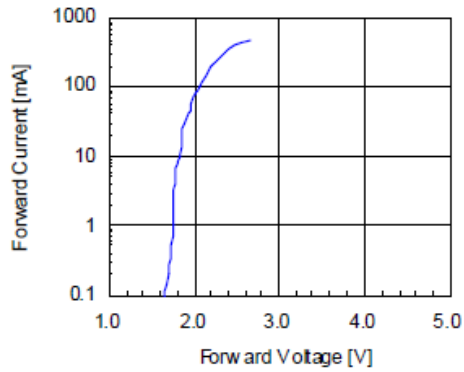

Fig 3. Forward Voltage vs. Temperature

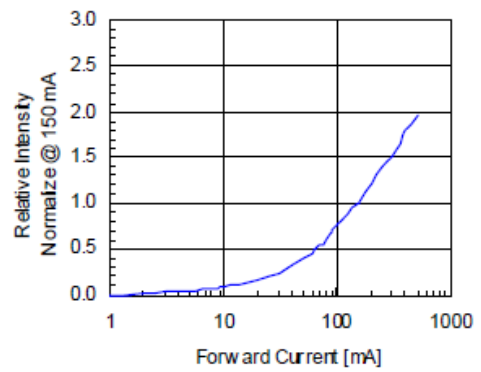

Fig 4. Relative Intensity vs. Temperature

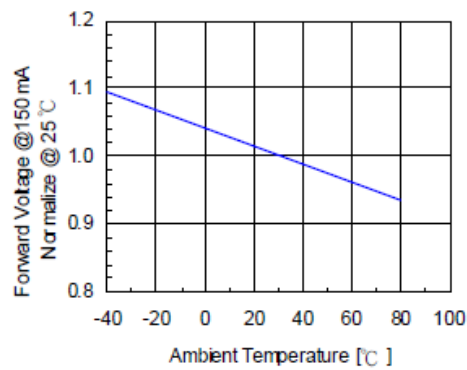
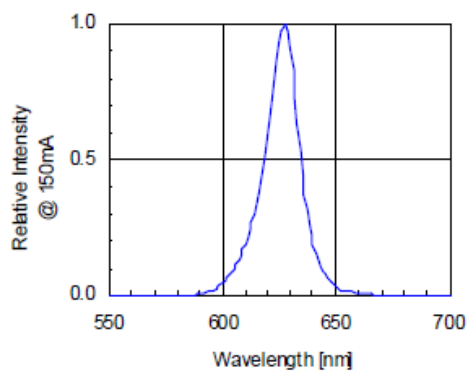
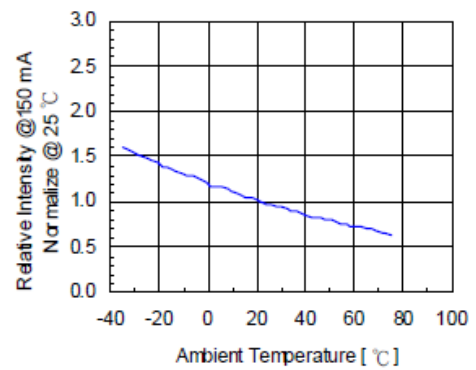

Fig 5. Relative Intensity vs. Wavelength





Soldering Profile

Reflow Soldering Profile For Lead-free SMT Process.

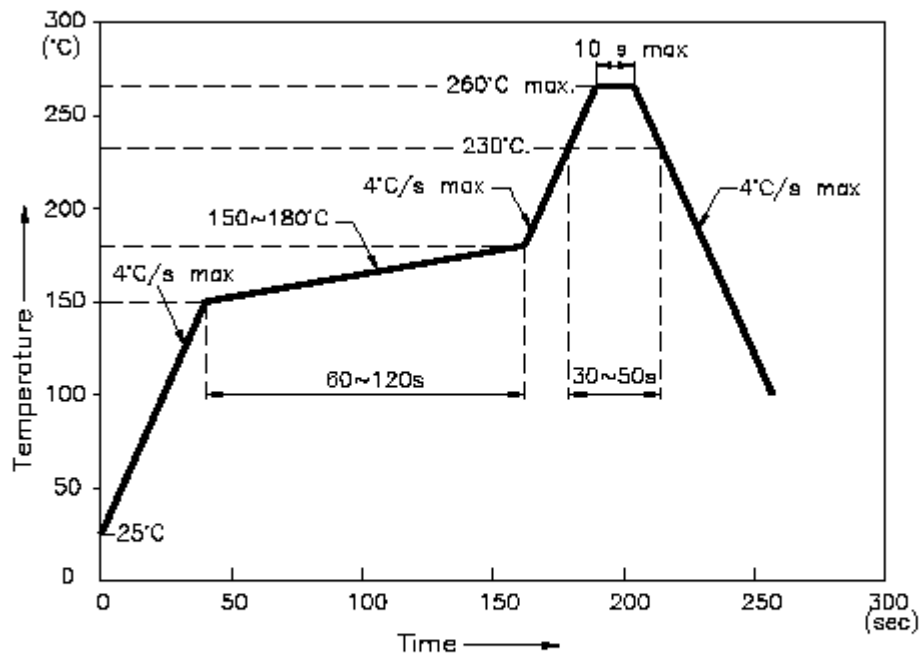

NOTES:

1. We recommend the reflow temperature 245°C(+/-5°C). The maximum soldering temperature should be limited to 260°C.
2. Don't cause stress to the epoxy resin while it is exposed to high temperature.
3. Number of reflow process shall be 2 times or less.



YETDA INDUSTRY LTD.

■Feeding Direction

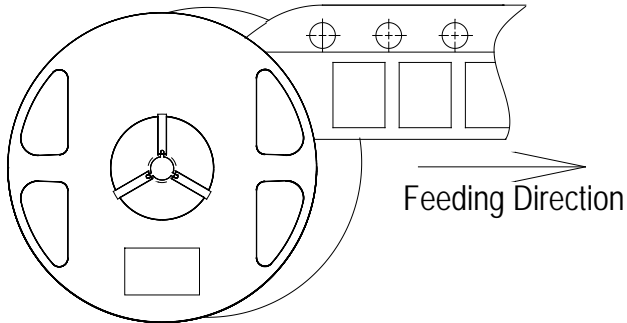

■Dimensions of Tape (Unit: mm)

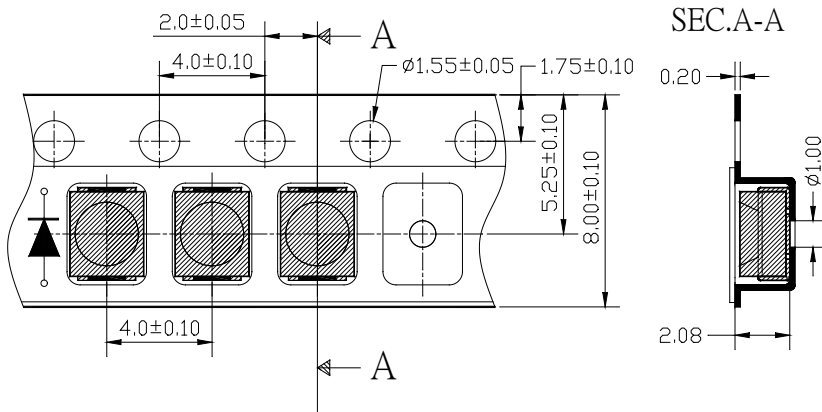

■Arrangement of Tape

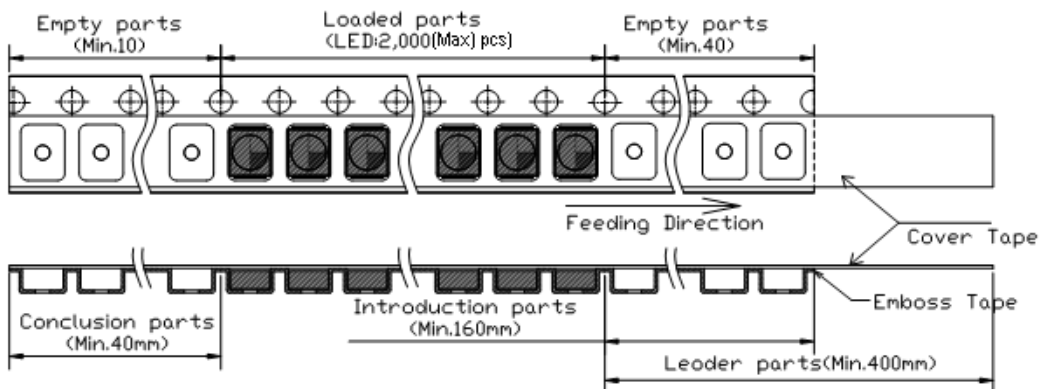

Notes:

1. Empty component pockets are sealed with top cover tape;
2. The maximum number of missing lamps is two;
3. The cathode is oriented towards the tape sprocket hole;
4. 2,000pcs/Reel