



YETDA INDUSTRY LTD.

Technical Data Sheet

MODEL NO : Q776Y4-50mA

3528 Package 3.5 x 2.8mm TOP LED

Features :

- Lens Molding
- Compatible with automatic placement equipment
- Compatible with reflow solder process

Applications :

- Indicators
- Automotive : backlighting in dashboard and switch
- Backlight for LCD

Dice material	Emitted color	Lens Color
AlGaInP	Yellow	Water transparent

Electrical/Optical Characteristics(Ta=25°C)

Parameter	Test Condition	Symbol	Value			Unit
			Min	Typ	Max	
Wavelength at peak emission	IF=50mA	$\Delta \lambda$		20		nm
Dominant wavelength	IF=50mA	λD	585	590	595	nm
Forward voltage	IF=50mA	VF	1.8	2.2	2.5	V
Luminous intensity	IF=50mA	Iv	3200	6500	11200	mcd
Viewing angle at 50% Iv	IF=50mA	$2 \theta 1/2$		25		Deg
Reverse current	VR=5V	IR			10	μ A

Absolute Maximum Ratings(Ta=25°C)

Parameter	Symbol	Value	Unit
Power dissipation	Pd	170	mW
Forward current	IF	70	mA
Reverse voltage	VR	5	V
Operating temperature range	Top	-40 ~+80	°C
Storage temperature range	Tstg	-40 ~+85	°C
Peak pulsing current (1/8 duty f=1kHz)	I _{fp}	125	mA

2018APR8Y



YETDA INDUSTRY LTD.

PACKAGING DIMENSIONS

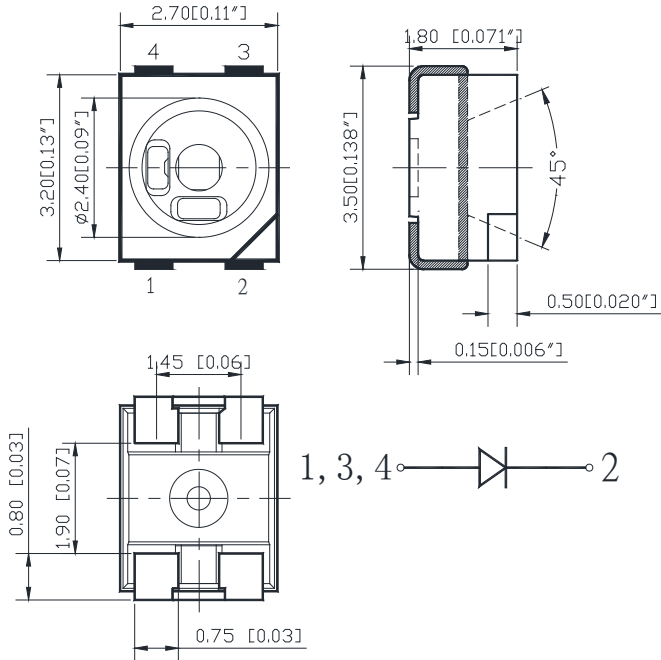

RECOMMEND PAD LAYOUT

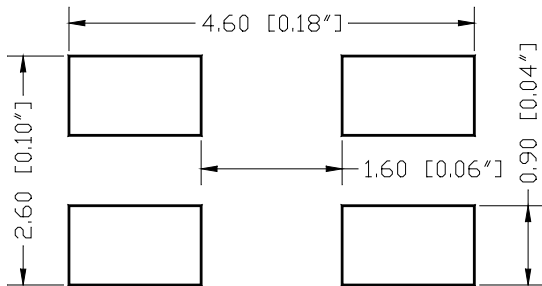



YETDA INDUSTRY LTD.

Typical Electro-Optical Characteristics Curve:

■ Typical Electro-Optical Characteristics Curve:

Fig 1. Forward Current vs. Forward Voltage

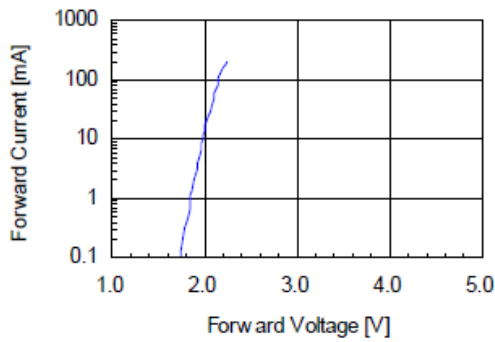

Fig 2. Relative Intensity vs. Forward Current

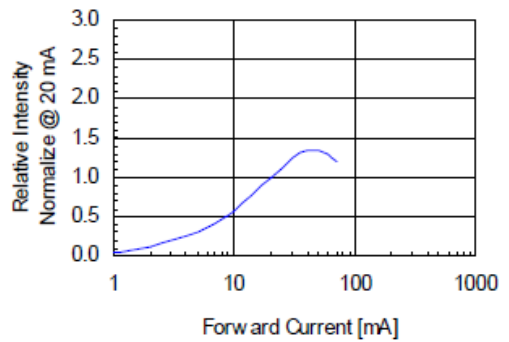

Fig 3. Forward Voltage vs. Temperature

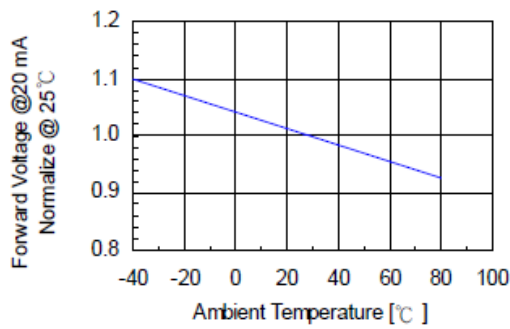

Fig 4. Relative Intensity vs. Temperature

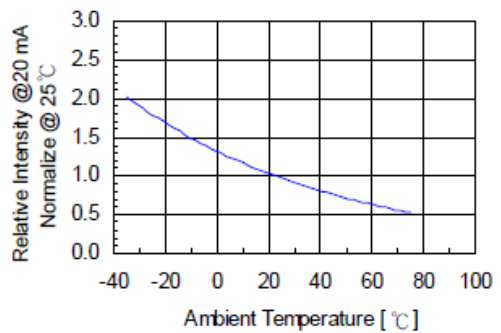
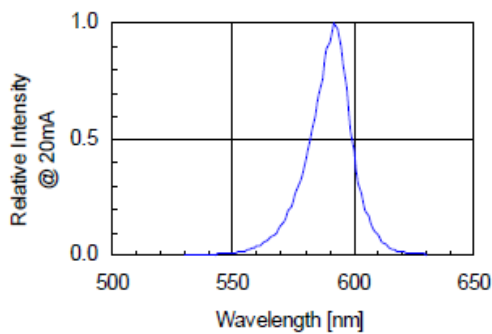

Fig 5. Relative Intensity vs. Wavelength





Soldering Profile

Reflow Soldering Profile For Lead-free SMT Process.

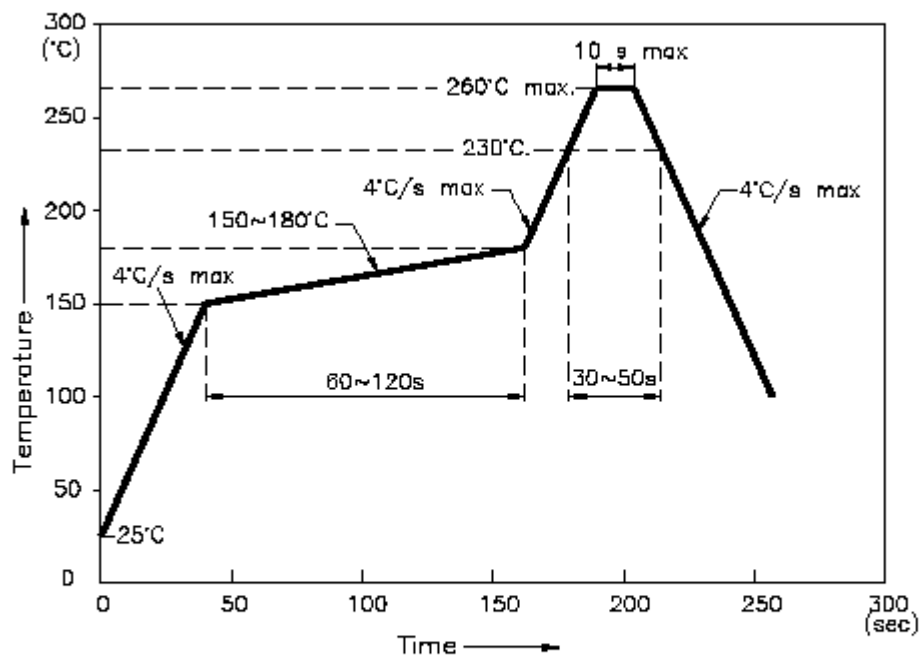

NOTES:

1. We recommend the reflow temperature 245°C(+/-5°C). The maximum soldering temperature should be limited to 260°C.
2. Don't cause stress to the epoxy resin while it is exposed to high temperature.
3. Number of reflow process shall be 2 times or less.



■ Feeding Direction

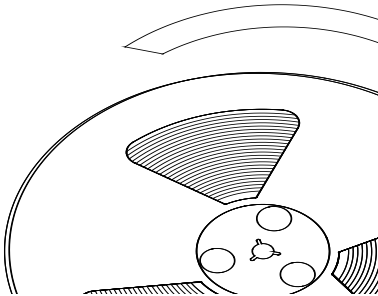

■ Dimensions of Tape (Unit: mm)

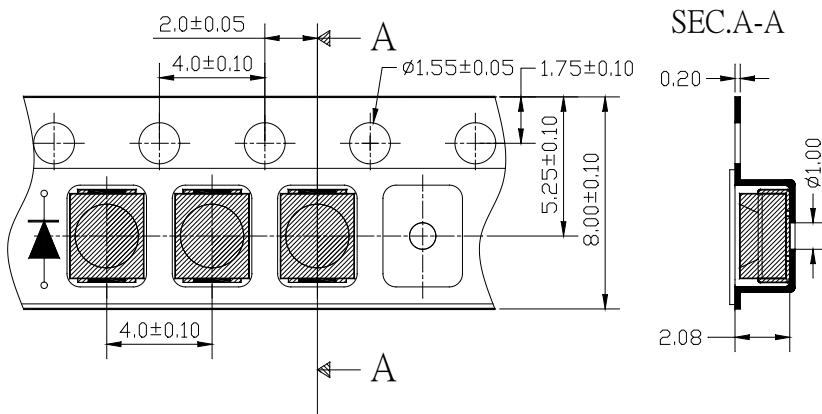

■ Arrangement of Tape

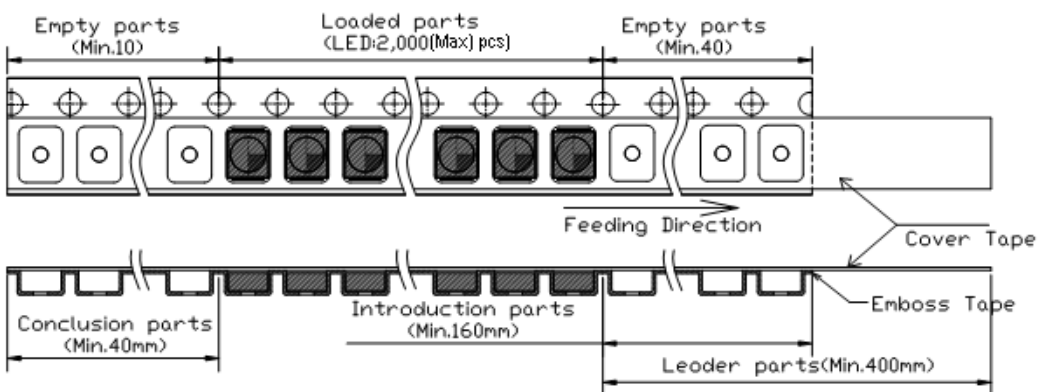

Notes:

1. Empty component pockets are sealed with top cover tape;
2. The maximum number of missing lamps is two;
3. The cathode is oriented towards the tape sprocket hole;
4. 2,000pcs/Reel