



YETDA INDUSTRY LTD.

Technical Data Sheet

MODEL NO : Q776Y4-PLK

3528 Package 2.8*3.2mm Chip LEDs

Features :

- Compatible with automatic placement equipment
- Compatible with reflow solder process

Applications :

- Indicators
- Automotive : backlighting in dashboard and switch
- Backlight for LCD

Dice material	Emitted color	Lens Color
AlGaInP	Yellow	Water Clear

Electrical/Optical Characteristics(Ta=25°C)

Parameter	Test Condition	Symbol	Value			Unit
			Min	Typ	Max	
Dominant wavelength	If=20mA	λ_{dom}	585	590	595	nm
Forward voltage	If=20mA	Vf	2.0		2.4	V
Luminous intensity	If=20mA	Iv	500		700	mcd
Viewing angle at 50% Iv	If=10mA	$2\theta_{1/2}$		120		Deg
Reverse current	Vr=5V	Ir			10	μ A

Absolute Maximum Ratings(Ta=25°C)

Parameter	Symbol	Value	Unit
Power dissipation	Pd	48	mW
Forward current	If	20	mA
Reverse voltage	Vr	5	V
Operating temperature range	Top	-40 ~+80	°C
Storage temperature range	Tstg	-40 ~+85	°C
Peak pulsing current (1/8 duty f=1kHz)	I _{fp}	20	mA

2018JAN13Y



YETDA INDUSTRY LTD.

PACKAGING DIMENSIONS

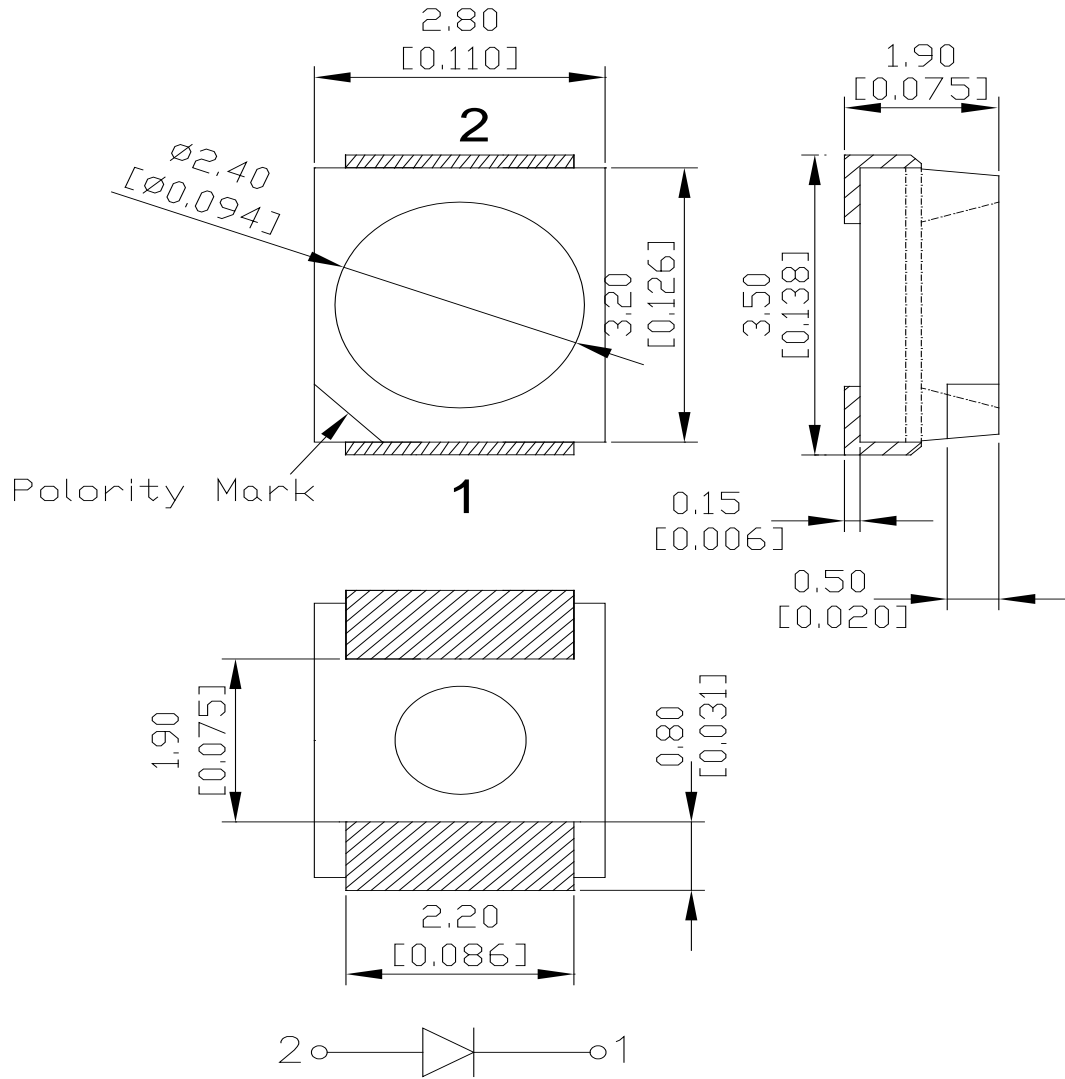

◆ **Recommended soldering pattern**
(Units:mm)

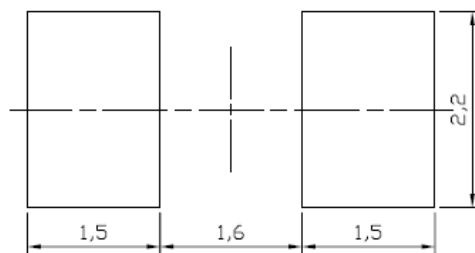



YETDA INDUSTRY LTD.

Typical Electro-Optical Characteristics Curve:

Fig 1. Forward Current vs. Forward Voltage

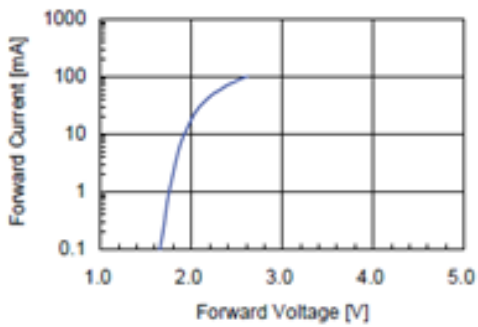

Fig 2. Relative Intensity vs. Forward Current

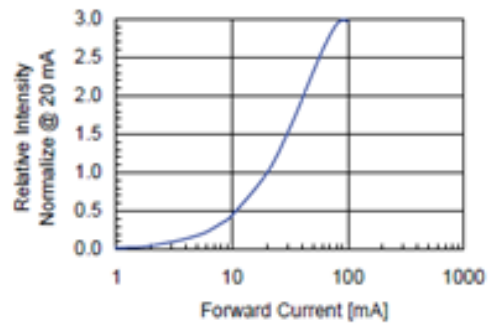

Fig 3. Forward Voltage vs. Temperature

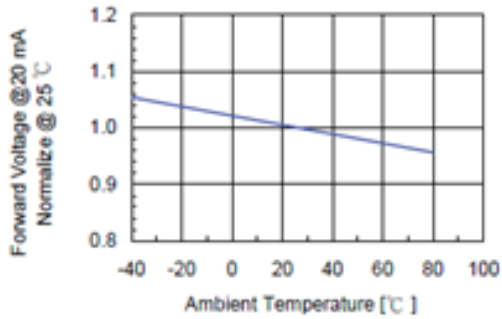

Fig 4. Relative Intensity vs. Temperature

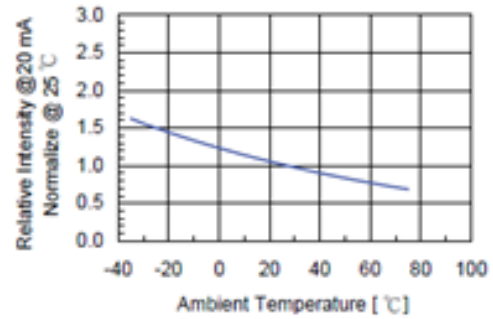
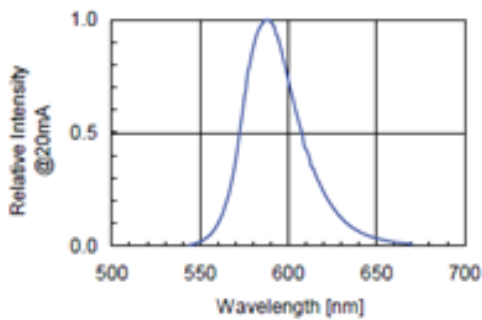

Fig 5. Relative Intensity vs. Wavelength





YETDA INDUSTRY LTD.

Precautions For Use :
Over - current - proof
Customer must apply resistors for protection, otherwise slight voltage shift will cause big current change (Burn out will happen)
Storage
1. The operation of temperature and R.H. are : $5^{\circ}\text{C} \sim 30^{\circ}\text{C}$, 60%R.H. Max.
2. Once the package is opened, the products should be used within a week. Otherwise, they should be kept in a dampproof box with desiccating regent. Considering the tape life, we suggest our customers to use our products within 1.5 year (from production date) .
3. It's recommended to bake before soldering when the package is unsealed after 72 hrs. The condition is : $60^{\circ}\text{C} \pm 5^{\circ}\text{C}$ for 15hrs.

■ Reflow Temp/Time

■ Temperature-profile (Surface of circuit board)

Use the following conditions shown in the figure.

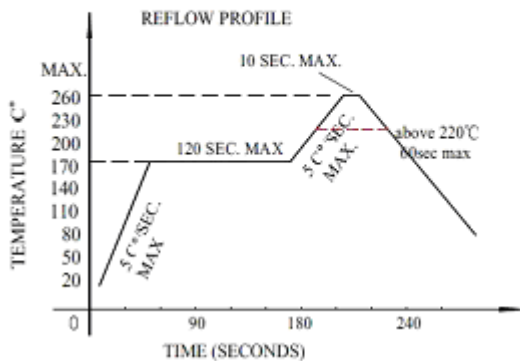

NOTES:

1. We recommend the reflow temperature $245^{\circ}\text{C} (\pm 5^{\circ}\text{C})$. the maximum soldering temperature should be limited to 260°C .
2. dont cause stress to the epoxy resin while it is exposed to high temperature.
3. Number of reflow process shall be 2 times or less.

■Soldering iron

Basic spec is $\leq 5\text{sec}$ when 260°C . If temperature is higher, time should be shorter ($+10^{\circ}\text{C} \rightarrow -1\text{sec}$). Power dissipation of iron should be smaller than 20W, and temperatures should be controllable. Surface temperature of the device should be under 230°C .

■Rework

1. Customer must finish rework within 5 sec under 260°C .
2. The head of iron can not touch copper foil
3. Twin-head type is preferred.



YETDA INDUSTRY LTD.

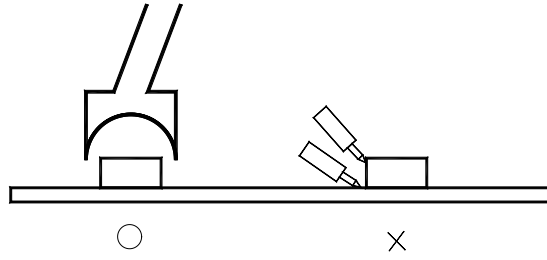

■ Avoid rubbing or scraping the resin by any object, during high temperature, for example reflow 、 solder etc.

■ Feeding Direction

■ Dimensions of Reel (Unit: mm)

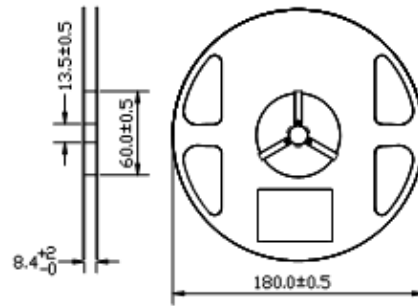
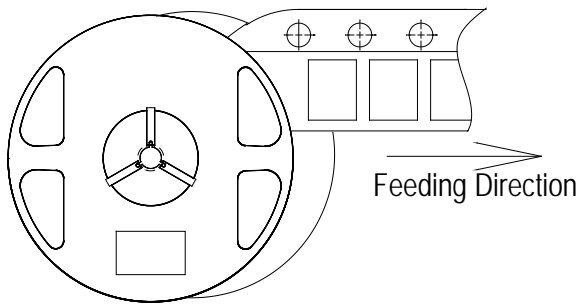

■ Dimensions of Tape (Unit: mm)

