



YETDA INDUSTRY LTD.

4" Single Digit Display

S-40011AY11

DESCRIPTION

- * 4" (101.6mm) Inch Digit Height.
- * Super Red Display.
- * Black Face and White Dot Color.
- * Common cathode.

ABSOLUT MAXIMUM RATINGS AT Ta=25°C

Parameter		UNIT
Power Dissipation Per Dot	40	mW
Peak Forward Current Per Dot	120	mA
Forward current Per Dot (Static)	15	mA
Reverse Voltage Per Dot	5	V
Operation Temperature Range	-25°C TO +80°C	°C
Storage Temperature Range	-25°C TO +100°C	°C
Solder Temperature 1/16 Inch Below Seating Plane For 5 Second At 260 °C		

ELECTRICAL/OPTOTICAL CHARACTERISTIC AT Ta=25°C

SUPER RED

PARAMETER	SYMBOL	MIN.	TYP.	MAX.	UNIT	CONDITION
Average Luminous Intensity	Iv	6	12		mcd	If=20mA
Peak Emission Wavelength	λp		590		nm	If=20mA
Forward Voltage Per Dot	Vf	10.5	13		V	If=20mA
Reverse Current Per Dot	Ir			10	uA	Vr=5V
Luminous Intensity Matching Ratio	Iv-m			2 : 1		If=20mA



YETDA INDUSTRY LTD.

P.C.B. Pin Connection

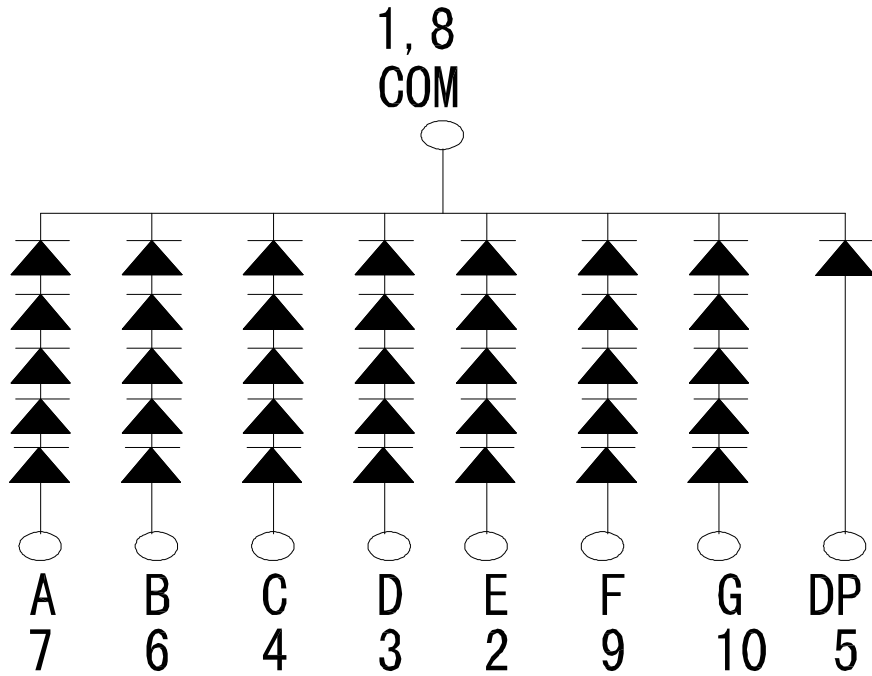

Reflector Dimensions

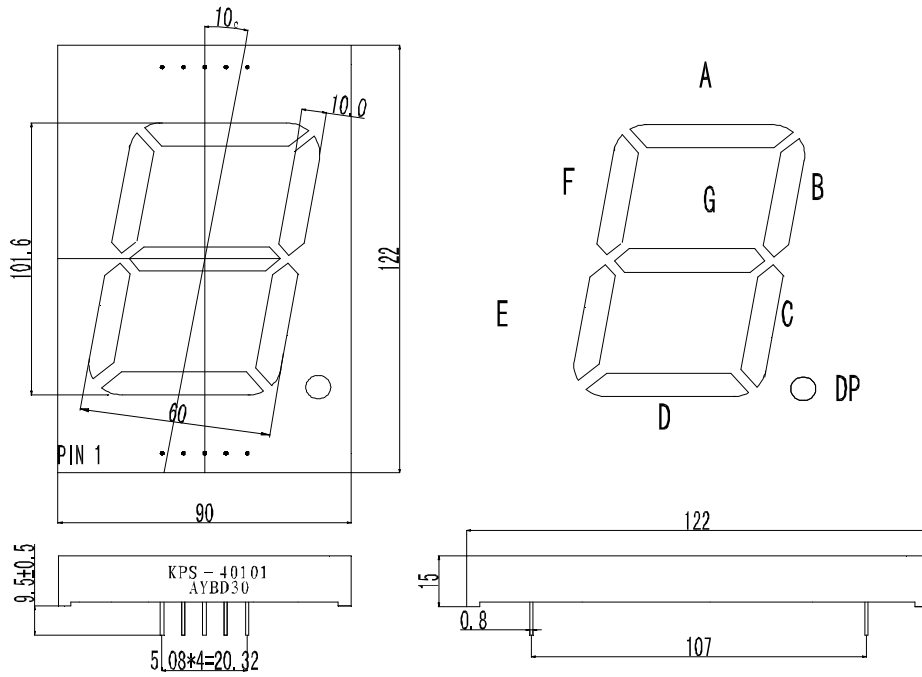



YETDA INDUSTRY LTD.

Typical Electro-Optical Characteristic Curves:

SPECTRAL DISTRIBUTION

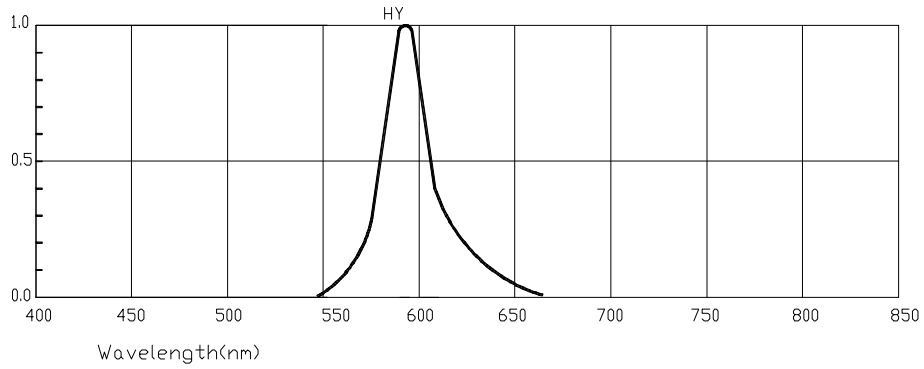

YELLOW (AlGaInP/GaAs)

FORWARD CURRENT VS FORWARD VOLTAGE

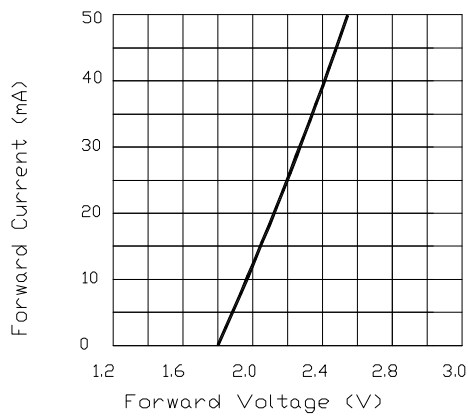

LUMINOUS INTENSITY VS FORWARD CURRENT

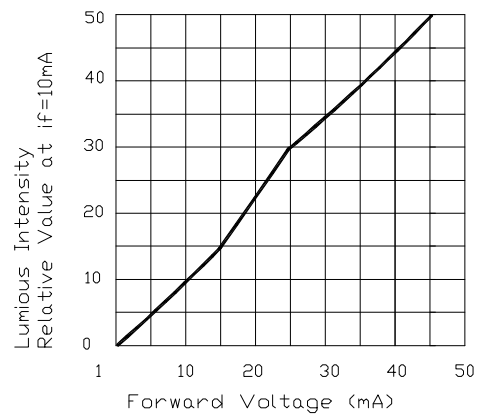

FORWARD CURRENT DERATING CURVE

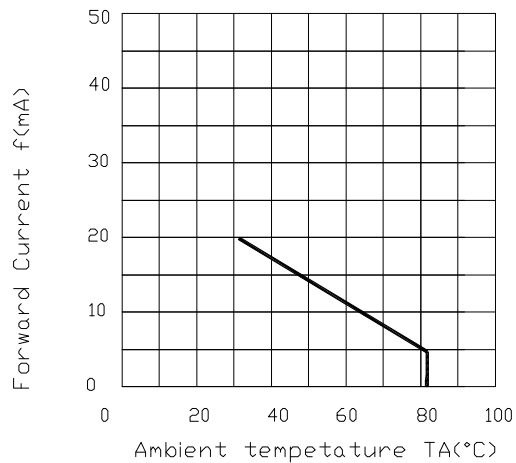

LUMINOUS INTENSITY VS AMBIENT TEMPERATURE

