

YETDA SIDE BACKLIGHT

Part Number	Chip			cd/m ²			VF (V)		
	Material	Emitter Color	λ_D (nm)	at $I_F=1mA$	Typ.	Max.	at $I_F=1mA$	Min.	Typ.

80×20mm LED Side Backlight With ESD Protection

UNIT:mm

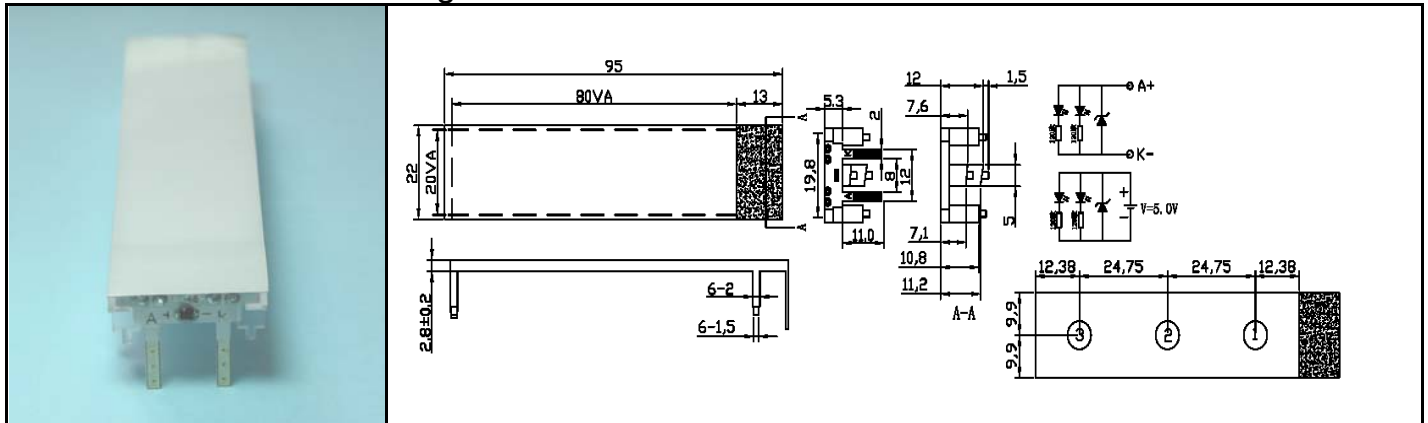

GRC5180B	InGaN	Blue	470	40	60	80	40	5	6
GRC5180W	InGaN	White	X:0.29 Y:0.30	40	80	100	40	5	6
GRC5180G	InGaN	Pure Green	525	40	120	150	40	5	6

54.6 x 31.3 x 2.6mm LED Side Backlight

UNIT:mm

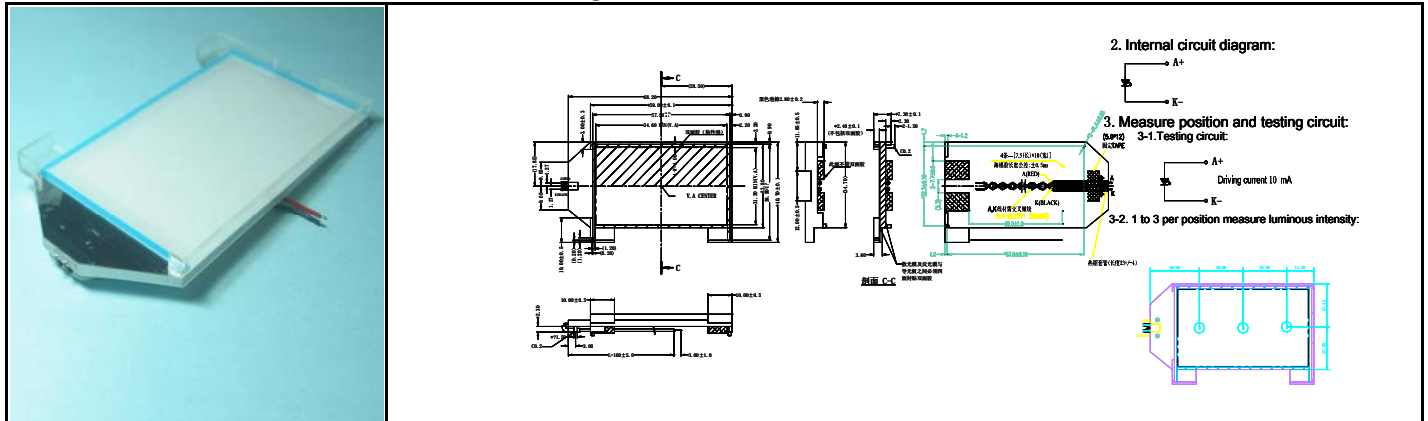

GRC7153YG	AlGaInP	Yellow Green	575	10	8.1	11.0	10	14	17
-----------	---------	--------------	-----	----	-----	------	----	----	----

Light Sources: Lamp	
Brightness: 15-2000cd/m ²	
Thickness: 1.5mm-3.5mm	
Length:20mm-150mm	
Wide:10mm-100mm	
Color	λD
Yellow Green	569-574nm
Blue	465-475nm
Pure-Green	520-530nm
Red	620-630nm
White	X:0.26-0.32 Y:0.26-0.32

