



YETDA INDUSTRY LTD.

5mm Blue Super Bright LED Lamps S500TB1D-H

- 5mm with InGaN dice ◦
- Encapsulated with Blue diffused lens package ◦
- Long Leads ◦

Absolute Maximum Ratings :

Parameter	Maximum Rating	Unit
Peak Forward Current	120	mA
Continuous Forward Current	30	mA
Operating Temperature Range	-40°C to +85°C	
Storage Temperature Range	-50°C to +100°C	
Lead Soldering Temperature	260°C for 3 seconds 1.6mm(0.063 inch) from body	

Electro-Optical Characteristics (Ta = 25°C)

Parameter Radiant	Test Condition	Symbol	Min.	Typ.	Max.	Unit
Forward Voltage	If = 20mA	Vf		3.2	3.8	V
Reverse Current	Vr = 5V	Ir			10	uA
Luminous Intensity	If = 20mA	Iv	650	1100		mcd
Spectral Bandwidth	If = 20mA	$\Delta\lambda$		35		nm
Wavelength	If = 20mA	λ_p				nm
		λ_d	465	470	475	nm
Viewing Angle	If = 20mA	2 θ 1/2		80		deg

Package

Item: 500

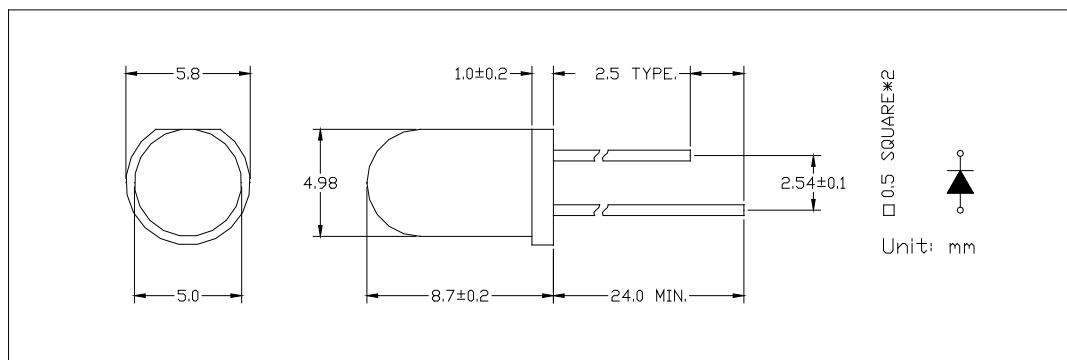



YETDA INDUSTRY LTD.

Typical Electro-Optical Characteristics Curve:

Fig 1. Forward Current vs. Forward Voltage

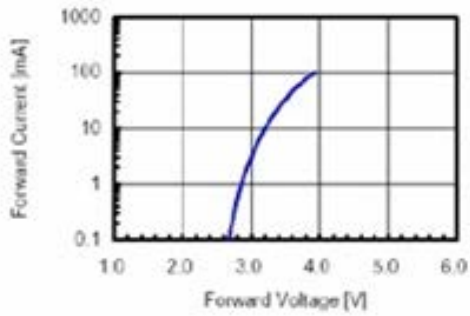

Fig 2. Relative Intensity vs. Forward Current

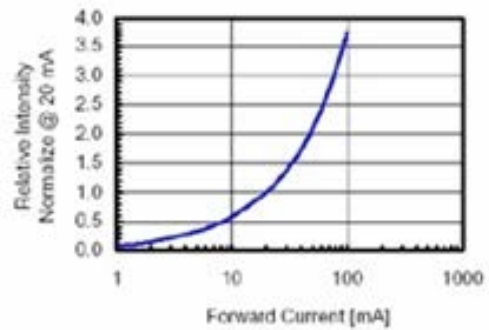

Fig 3. Forward Voltage vs. Temperature

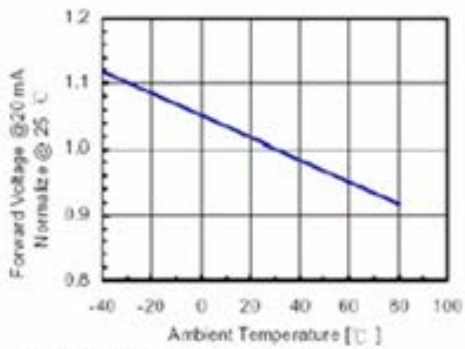

Fig 4. Relative Intensity vs. Temperature

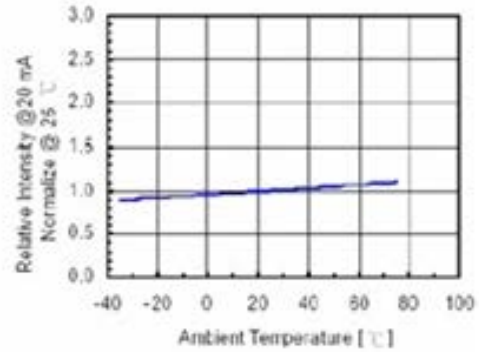
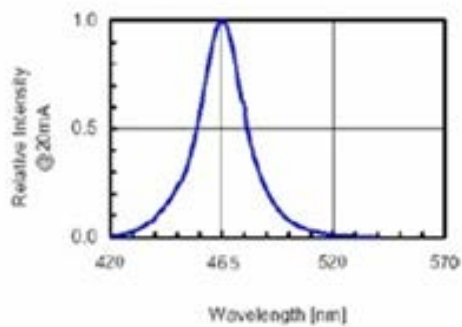

Fig 5. Relative Intensity vs. Wavelength





YETDA INDUSTRY LTD.

•Soldering:

1. Manual of soldering

The temperature of the iron tip should not be higher than 260 °C and

Soldering within 3 seconds per solder-land is to be observed

2. DIP soldering (Wave Soldering):

Preheating: 120 °C ~ 150°C within 5 sec. 260°C (Max)

Gradual Cooling (Avoid quenching)

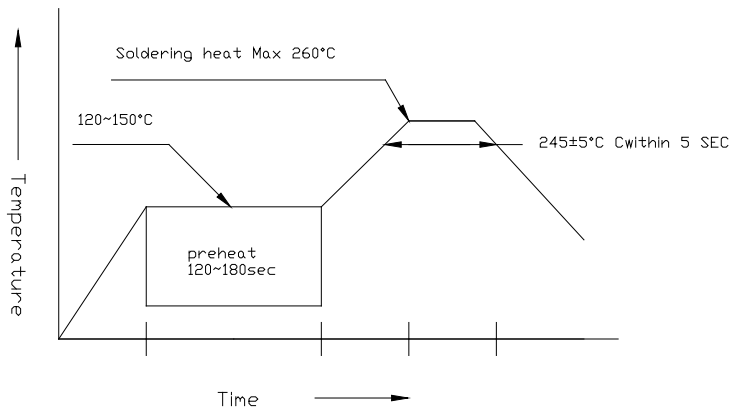

3. Reflow Soldering

Preheating: 140 °C ~ 160°C ±5°C, within 2 minutes.

Operation heating: 235 °C (Max) 10 seconds (Max)

Gradual Cooling (Avoid quenching)

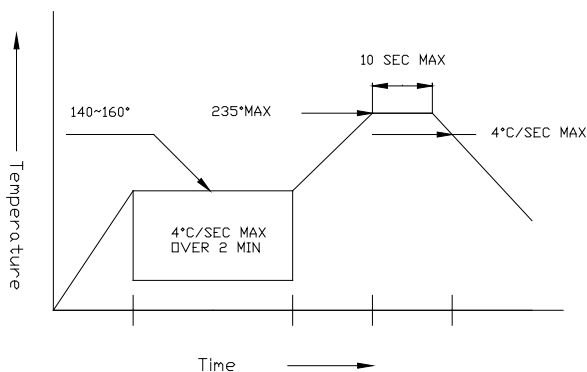

•Handling:

Care must be taken not to cause to the epoxy resin portion of Yetda LEDS while it is exposed to high temperature.

Care must be taken not rub the epoxy resin portion of Yetda LEDS with hard or sharp article such as the sand blast and the metal hook