



# YETDA INDUSTRY LTD.

## 5W HIGH POWER LED MODULE W5R22\*15

Features	Applications
* Long operating life	* Reading lights (car, bus, aircraft)
* Highest flux	* LCD Backlights/light Guides
* Available in White:2500K-25000K	* Fiber optic alternative/ Decorative Entertainment
* Lambertian radiation pattern	* Mini-accent/Up lighters/Down lighters/ Orientation
* More energy efficient than incandescent and most halogen lamps	* Indoor/Outdoor commercial and Residential Architectural
* Low voltage DC operated	* Cove/Under shelf/Task
* Cool beam, safe to the touch	* Bollards/Security/Garden
* Instant light (less than 100ns )	* Portable (flashlight, bicycle)
* Fully dimmable	* Edge-lit signs (Exit, point of sale)
* No UV	* Automotive Exit (Stop-Tail-Turn,CHMSL, Mirror Side Repeat)
* Superior ESD protection	* Traffic signaling / Beacons / Rail Crossing and Wayside
* Eutectic die bonding	
* RoHS compliant	

### PACKAGE

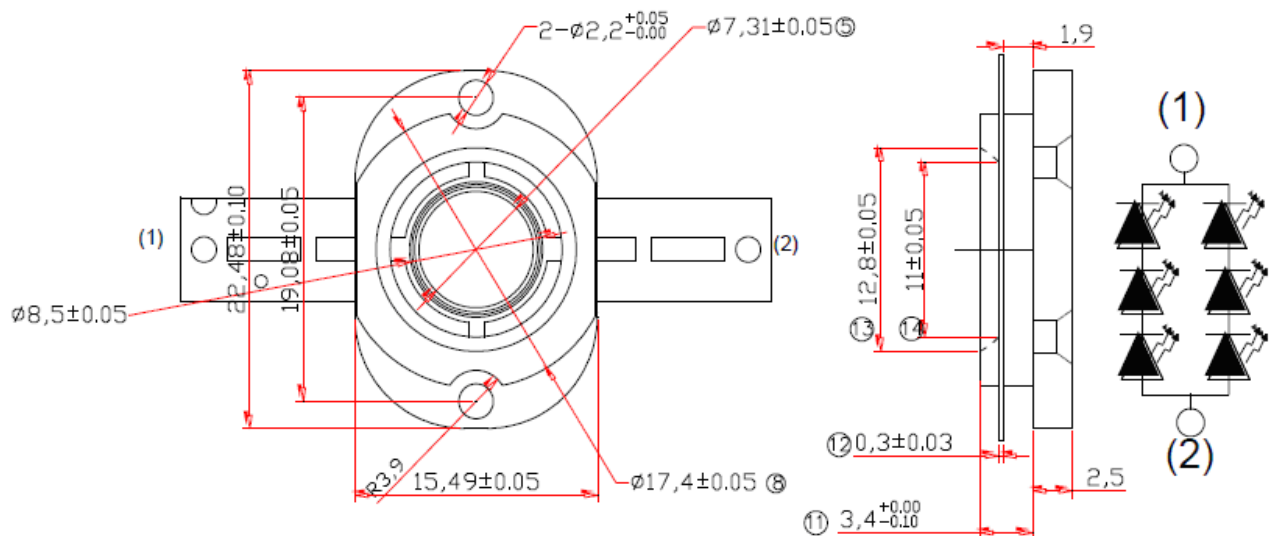



# YETDA INDUSTRY LTD.

## Typical Optical/ Electrical Characteristics @T<sub>J</sub>=25°C

Item	Symbol	Condition	Min.	Typ.	Max.	Unit
Forward Voltage	V <sub>F</sub>	I <sub>F</sub> =700mA	6.0	6.4	7.0	V
Reverse Current	I <sub>R</sub>	V <sub>R</sub> =5V	0		5	uA
Viewing Angle	2θ <sub>1/2</sub>	I <sub>F</sub> =700mA		120		deg
Luminous Intensity	φ <sub>V</sub>	I <sub>F</sub> =700mA	450		500	lm
Chromaticity	T <sub>C</sub>	I <sub>F</sub> =700mA	6000		6500	k

### Notes:

1. Tolerance of measurement of forward voltage±0.1V.
2. Tolerance of measurement of peak Wavelength±2.0nm.
3. Tolerance of measurement of luminous intensity±15%.

## Absolute Maximum Rating

Item	Symbol	Absolute Maximum Rating	Unit
Forward Current	I <sub>F</sub>	1000	mA
Operation Temperature	T <sub>OPR</sub>	-25~+75	°C
Storage Temperature	T <sub>STG</sub>	-40~+80	°C
Lead Soldering Temperature*	T <sub>SOL</sub>	Max. 350°C for 3sec Max.	

\*IFP Conditions : Pulse Width≤10msec duty≤1/10

- \* All high power emitter LED products mounted on aluminum metal-core printed circuit board, can be lighted directly, but we do not recommend lighting the high power products for more than 5 seconds without a appropriate heat dissipation equipment.
- \* Re-flow, wave peak and soak- stannum soldering etc.is not suitable for this products.
- \* Suggest to solder it by professional high power LED soldering machine.
- \* Can use invariable-temperature searing-iron with soldering condition≤ 350 degree less than 3 seconds.



# YETDA INDUSTRY LTD.

## Typical Electro-Optical Characteristics Curve:

